

Gebrauchsanleitung

Weintemperierschrank

Seite 2

Operating Instructions

Wine Cooler

Page 16

Gebruiksaanwijzing

Wijnklimaatkast

Pagina 30

Consignes d'utilisation

Armoire de mise en température des vins

Page 44

Instrucciones de manejo

Armario bodega para acondicio- namiento de vinos

Página 58

Istruzione d'uso

Cantina temperata per vini

Pagina 72



Many thanks for your trust.

Congratulations on your purchase of this wine cooler. In buying this product, which is distinguished by its perfect user-friendliness, impeccable reliability and high quality, you have chosen a top class appliance. We wish you a lot of pleasure with your new wine cooler - and a lot of enjoyment from your wines.

The fewer the grapes produced in an area, the better the wine.

Poor, well-drained soils are best for good wines. The properties of the soil influence the vitality of the vine, which in turn affects the quality of the grape. Climate is another factor that is important for wine. Because light and air humidity are important for the development of the flavour of the wine.

The right environment for your wines.

A vine is an extremely sensitive plant. From the time it is planted to its maturing period and the time the grapes are harvested and the wine is made, it is dependent on three factors: light, air humidity and ambient temperature. This sensitivity continues even once the wine is bottled. To allow the flavour of the wine to fully develop or to preserve the excellent aroma, the wine has to be stored perfectly - and your wine cooler offers the best conditions for this.



Contents

	Page
Setting up, Dimensions	18
Electrical requirements	18
Operating and control elements	19
Switching the appliance on and off	19
Setting the temperature	20
Fan button.....	20
Additional functions	21
Audible warning signal	21
Equipment.....	22
Interior light.....	23
Storage diagram	23
Defrosting, Cleaning	24
Malfunctions	25
Shutting your appliance down	25
Changing over door hinges.....	26
Safety instructions and warnings.....	28
General information.....	28
Disposal notes.....	29

Description of appliance and equipment

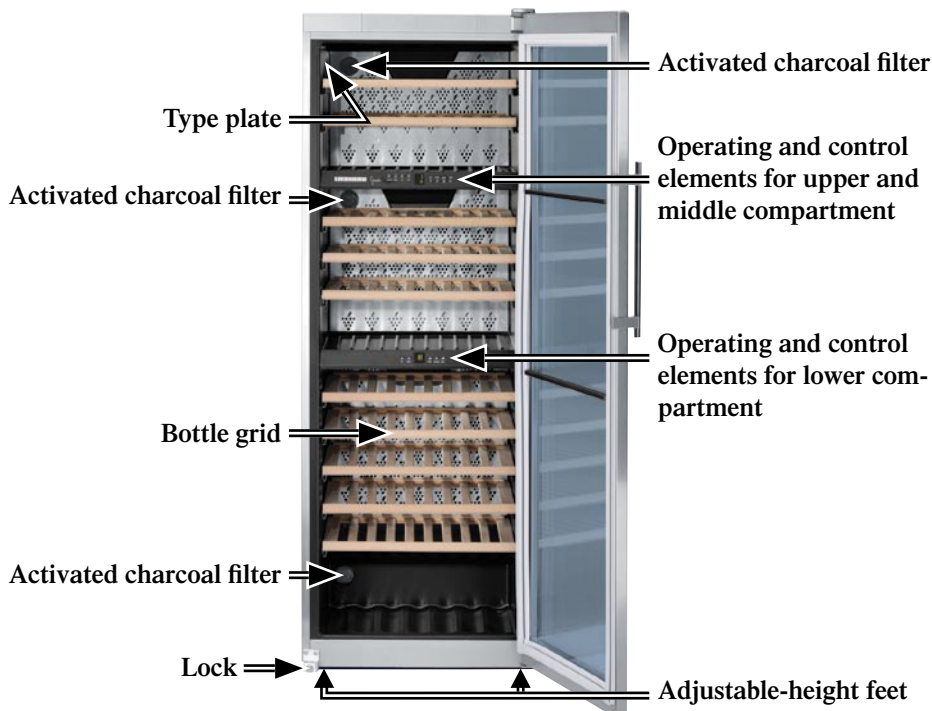

Setting up

- Avoid positioning the appliance in direct sunlight or near heat sources such as an oven or a radiator.
- The floor should be level and even. You can compensate for an uneven floor by adjusting the adjustable feet.
- Please make sure the appliance is properly ventilated.
- Standard EN 378 specifies that the room in which you install your appliance must have a volume of 1 m³ per 8 g of R 600a refrigerant used in the appliance, so as to avoid the formation of inflammable gas/air mixtures in the room where the appliance is located in the event of a leak in the refrigerant circuit. The quantity of refrigerant used in your appliance is indicated on the type plate on the inside of the appliance.
- The appliance is set to operate within specific ambient temperature limits according to its climate rating. These temperature limits should not be exceeded. The correct climate rating for your appliance is indicated on the type plate.
SN - ST = +10°C to +38°C
SN - T = +8°C to +43°C

Dimensions

WT 4677: height: 1855 mm, width: 660 mm, depth: 671 mm

Electrical requirements

Power supply (AC) and voltage at the operating point must comply with the details on the type plate. The type plate is located on the top left-hand side on the inside of the appliance. The socket must be fused with a 10 A fuse or higher, it must be away from the rear of the appliance and must be easily accessible.

Operating and control elements for upper and middle compartment



- ❶ Upper compartment temperature display
- ❷ Child-proof lock
- ❸ Middle compartment temperature display
- ❹ Interior light on/off button
- ❺ Audible warning on/off button
- ❻ On/off button
- ❼ Middle compartment temperature setting buttons
- Ⓣ Fan button
- ❽ Upper compartment temperature setting buttons
- Ⓢ Alarm
- ❾ Fan button
- Ⓛ Light

Operating and control elements for lower compartment



- ❶ Temperature display
- ❷ Temperature setting buttons
- ❸ Audible warning on/off button
- ❹ Fan button
- ❺ Child-proof lock
- ❻ On/off button

Switching the appliance on and off

You are recommended to clean the appliance before switching it on for the first time (see **Cleaning**). Connect the appliance to the mains - the appliance is switched on.

- **To switch the appliance off:** Keep the ON/OFF button pressed for approx. 3 sec. so that the temperature display goes out.
- **To switch the appliance on:** Press the ON/OFF button until the temperature display lights up.



Note: The two control systems can be switched on and off separately.

Setting the temperature

The temperature of all compartments can be set separately.

- 1 Upper compartment
- 2 Middle compartment
- 3 Lower compartment

To reduce the temperature:

Press the DOWN button.

To increase the temperature:

Press the UP button.

- While you are entering the temperature, the set temperature will flash on the display.
- You can change the settings in increments of 1°C briefly pressing the button again.
- The electronic control system will switch over automatically about 5 seconds after the last time you pressed the button, and the actual temperature will be displayed.

The following drinking temperatures are recommended for the various types of wine.

Red wines: +14°C to +18°C

Rosé wines: +10°C to +12°C

White wines: +8°C to +12°C

Sparkling wines, Prosecco +7°C to +9°C

Champagne +5°C to +7°C

If *F0* or *F1* appears in the display, the appliance has a fault. Consult your nearest customer service point.

Fan button

Should you wish to use the wine cooler to store wine for long periods of time, activate the "Ventilation" button. The light in the button comes on. Thereby a climate which corresponds to that of a wine cellar is achieved inside the wine cooler. Corks are prevented from drying out due to an increased level of humidity.

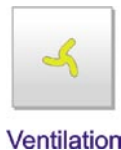

Additional functions

In set-up mode you can set the child-proof lock and adjust the brightness of the display. The child-proof lock is designed to protect the appliance from being switched off accidentally.

Activating set-up mode:

- Press the fan button for approx. 5 secs - the fan button flashes - the display shows **c** for child-proof lock.

Note: the value to be altered flashes.

- Select the required function by pressing the Up/Down button:

c = child-proof lock, **h** = display brightness

- Now select/acknowledge the function by pressing the fan button briefly:

> For **c** = child-proof lock,

press the Up/Down button to select

c1 = child-proof lock on or

c0 = child-proof lock off and acknowledge with the fan button.

When the symbol ☺ is lit, the child-proof lock is activated.

> For **h** = brightness, press the Up/Down button to select

h1 = minimum to

h5 = maximum brightness and acknowledge with the fan button.

Exiting set-up mode: Exit the set-up mode by pressing the On/Off button; after 2 min. the electronic system switches over automatically. The normal operating mode is activated again.

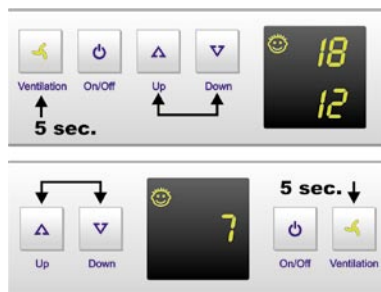

Audible warning signal

The audible warning signal helps to protect your wines against excessive temperature fluctuations.

- It sounds when the door has been left open for longer than about 60 seconds. The audible warning device is switched off by pressing the **Alarm** button.
- It sounds when the interior gets too warm or too cold. The temperature display will also flash. The audible warning device is switched off by pressing the **Alarm** button. The temperature display will continue to flash until the cause of the alarm has been rectified.

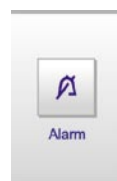

Equipment

Pull-out shelf

The pull-out shelf allows bottles of wine to be removed more easily.

Labels

The appliance is supplied with a label holder with labels for each shelf. Use these to label the type of wine stored on each shelf. Use a soft pencil on the labels so that you can erase it again when necessary. Additional labels can be obtained from your dealer.

Fitting: Click the label holder into place and slide the label in from the side.



Safety lock

Locking the appliance:

- Insert the key as shown by arrow 1.
- Turn the key 90°.

To unlock the appliance, the same procedure must be repeated in the same order.

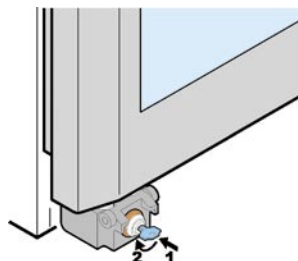

Air exchange with activated charcoal filter

The way in which wines continue to mature depends on the ambient conditions. The quality of the air is therefore decisive for preserving the wine.

We recommend that you replace the filter once a year. Filters can be obtained from your dealer.

Changing the filter: Take the filter by the handle. Turn it 90° to the left or right and remove.

Inserting the filter: Insert with the handle in a vertical position. Turn it 90° to the left or right until it clicks into place.



Interior light

The interior light can be switched on and off using the "Light" button.

Caution - class 1M laser radiation. When cover is removed, do not look directly at light through optical instruments.

The interior light may only be replaced by the customer service technician or by competent skilled personnel!



Furthermore, the brightness of the lighting can be adjusted.

- Press the "Light" button. The indicator lamp in the button will light up.
- Press and hold the "Light" button and at the same time press the temperature setting buttons to increase or decrease the brightness.
Down = darker, UP = brighter.

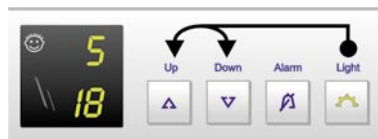

Note: The brightness will change in all compartments.

Storage diagram

for 750 ml Bordeaux bottles

Total: 143 bottles

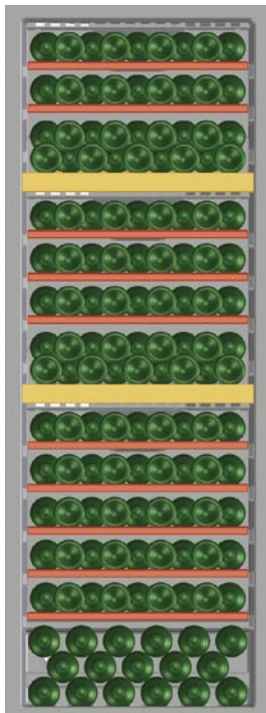

Defrosting

The appliance defrosts automatically. The water that forms on the rear wall drains into a reservoir at the back of the appliance and evaporates automatically through the compressor heat.

Cleaning

Before cleaning always switch off the appliance. Pull out the mains plug or remove/unscrew the fuse.

Never use abrasive or acidic cleaning agents or chemical solvents. We recommend the use of an all-purpose cleaner with neutral pH.

Do not use steam cleaners because of the risk of injury and damage.

- Do not use abrasive sponges or scourers, do not use concentrated cleaning agents and never use cleaning agents containing sand, chloride or acid or chemical solvents, as these would damage the surfaces and could cause corrosion.
- Use a glass cleaner to clean the glass surfaces and a commercially available stainless-steel cleaning agent for the stainless-steel surfaces.
- Clean the inside and equipment with lukewarm water and a little detergent, with the exception of the wooden trims on the grid shelves.
- Ensure that no cleaning water penetrates into the electrical components.
- Dry all parts well with a cloth.
- Do not remove the type plate from the inside of the appliance; it is important for after-sales servicing.

Malfunctions

Your appliance is designed and manufactured for a lengthy, reliable operating life with no malfunctions. If a malfunction nonetheless occurs during operation, check whether it is due to an operating error. Please note that even during the warranty period the resultant servicing costs in this case will have to be borne by the owner.

You may be able to rectify the following faults by checking the possible causes yourself:

- **Appliance does not function:**
 - Check that the appliance is properly connected to the mains.
 - Is the socket fuse intact?
- **Loud running noise:** Check that the appliance is standing firmly on the ground. Please note that it is impossible to avoid flowing noises in the refrigeration circuit.
- **The temperature inside your wine cooler is too warm:** Check the setting in accordance with the section "Setting the temperature".
 - Does the separately installed thermometer show the correct reading?
 - Is the air extraction working properly?
 - Is the wine cooler too close to a heat source?
- Please note that, as can happen with other forms of storage, slight mould may form depending on the type of adhesive on the labels. This can be rectified by carefully cleaning any adhesive residues off the bottles.

If none of the above causes apply and you cannot rectify the fault yourself, contact the nearest customer service department stating the type designation ①, index ② and appliance number ③ as indicated on the type plate. The type plate is located on the left-hand inside wall.

①		②	
II III II Index II / III			
Service-Nr. / No.Service: IIIIII - II			
SERIE			
SERIENR.			
KLASSE	BRUTTOINHALT	NUTZINHALT	GES / K / G / KE / BIO
CLASS	GROSS CAPACITY	NET CAPACITY	TOT / R / F / CE / BIO
CLASSE	VOLUME BRUT	VOLUME UTILE	TOT / R / C / CA / BIO
CLASE	CAPACIDAD BRUTA	CAPAC. UTIL	TOT / F / C / BO / BIO
II	II	II I	II I
TYP	GEFRIERVERMÖGEN		
TYPE	FREEZING CAP		
TIPO	POUVOIR DE CONGEL.		
III I	CAPAC. CONGELADORA		
R IIIa : III G			
AC III-III V II Hz III W			
			 ③ <small>DEW 88 000000</small>

Shutting your appliance down

If your appliance is to be shut down for any length of time, switch it off and disconnect the plug or remove the fuse. Clean the appliance and leave the door open in order to prevent unpleasant smells.

Changing over door hinges

1

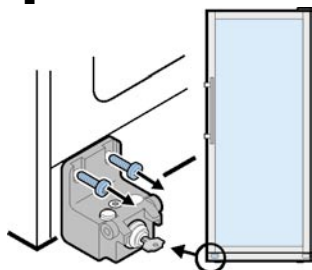

Unscrew lock bracket.

2

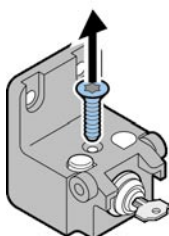

Remove screw.

3

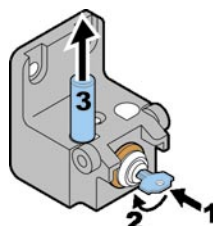

Insert key **1**, turn **2**, and remove pin **3**.

4

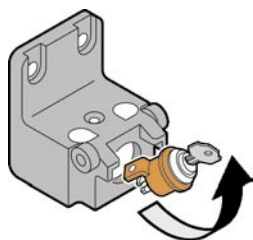

Remove lock.

5

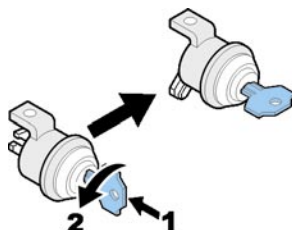

Insert key **1** and turn **2**.

6

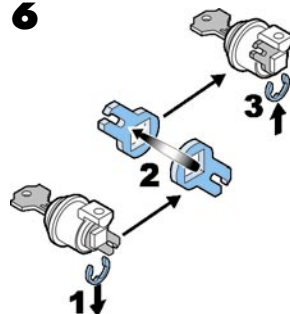

Remove door latch **1**, turn over **2** and reassemble **3**.

7

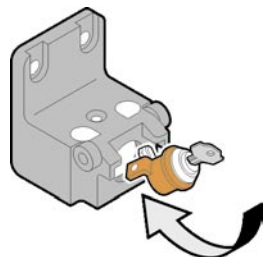

Insert lock.

8

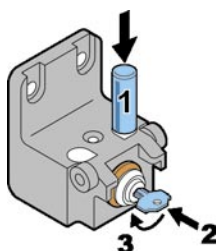

Insert pin **1**, insert key **2** and turn **3**.

9

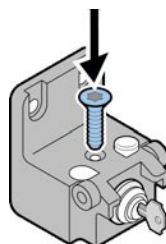

Insert screw.

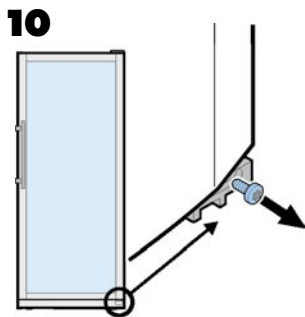

10
Remove screw from lower hinge bracket.

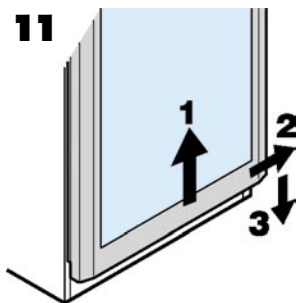

11
Lift door **1**, tilt to the right **2** and remove **3**.

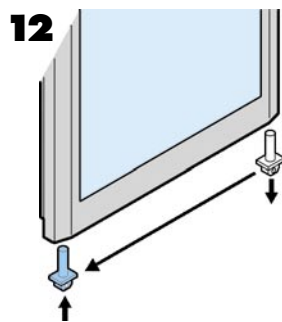

12
Transfer pin to the opposite side of the door.

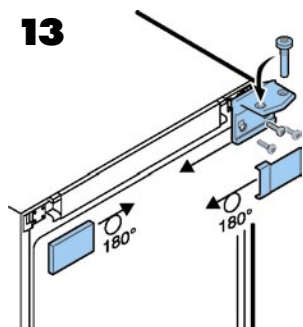

13
Transfer upper hinge components to the opposite side.

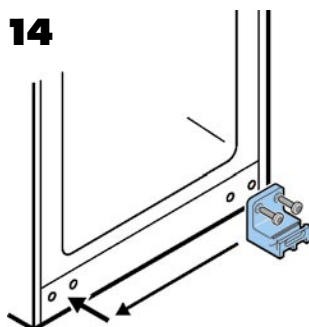

14
Transfer lower hinge bracket to the opposite side.

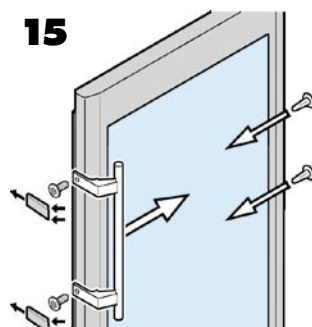

15
Transfer handle to the opposite side.

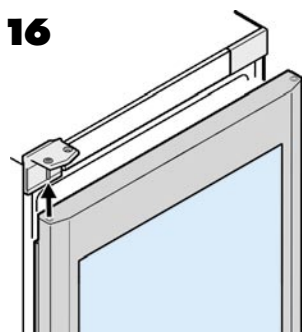

16
Locate door on upper pin.

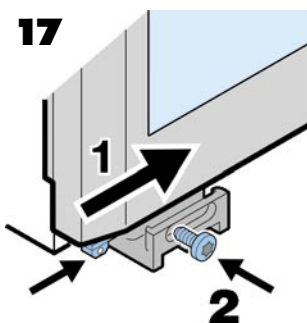

17
Tilt door inwards from the left **1**. Secure hinge pin with screw **2**.

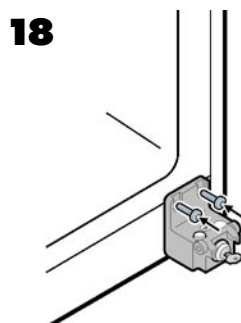

18
Screw on lock bracket.

Safety instructions and warnings

- To prevent injury or damage to the unit, the appliance should be unpacked and set up by two people.
- In the event that the appliance is damaged on delivery, contact the supplier immediately before connecting to the mains.
- To guarantee safe operation, ensure that the appliance is set up and connected as described in these operating instructions.
- Disconnect the appliance from the mains if any fault occurs. Pull out the plug, switch off or remove the fuse.
- When disconnecting the appliance, pull on the plug, not on the cable.
- **Any repairs and work on the appliance should only be carried out by the customer service department, as unauthorised work could prove highly dangerous for the user. The same applies to changing the mains power cable.**
- Do not stand on the plinth, drawers or doors or use them to support anything else.
- This appliance is not intended for use by persons (including children) with reduced physical, sensory or mental capabilities or lack of experience and knowledge unless they have been given initial supervision or instruction concerning use of the appliance by a person responsible for their safety. Children should be supervised to ensure that they do not play with the appliance.
- Avoid prolonged skin contact with cold surfaces or chilled/frozen food. This could cause pain, numbness and frostbite. In the case of prolonged skin contact, protective measures should be taken, e.g. gloves should be worn.
- **If you have a lockable appliance, do not keep the key near the appliance or within reach of children.**
- Do not use electrical appliances inside the appliance.

General information

The refrigerant circuit has been tested for leaks.

The appliance is radio-suppressed to EN 55014 and thus complies with EC Directive 87/308/EEC.

All types and models are subject to continuous improvement and the manufacturer therefore reserves the right to make modifications to the shape, equipment and technology.

Disposal notes

The packaging is made of recyclable materials.

- Corrugated board/board
- EPS moulded parts
- Polythene sheets
- Polypropylene straps

- **Keep packaging materials away from children - polythene sheets and bags can cause suffocation!**
- Please return the packaging material to an official collection point.

Your old appliance: This contains some reusable materials and should be disposed of properly - not simply with unsorted household refuse.

- Disable discarded appliances by removing the plug and cutting through the connection cable. Render the catch unusable so that children cannot become trapped inside.
- Make sure that the refrigerant circuit of an appliance that is no longer needed is not damaged before it is collected or handed in at a municipal collection point.
- Details of the refrigerant used can be found on the type plate.
- Information on collection dates or collection points can be obtained from the waste disposal authorities or local council.

